

ATELIERS D'ART FRANÇAIS

information required
for an estimate for

BULL'S EYE

Umicore France s.a.
Ateliers d'Art Français
Les Mercuriales
40, rue Jean Jaurès
93176 Bagnole Cedex

Tel.: +33 1 49 72 43 40
Fax: +33 1 49 72 43 42

www.ornementation.com
www.ateliersdartfrancais.fr
ateliersdartfrancais@umicore.com

A Umicore brand



TAILOR-MADE BULL'S EYE

INFORMATION REQUIRED FOR AN ESTIMATE

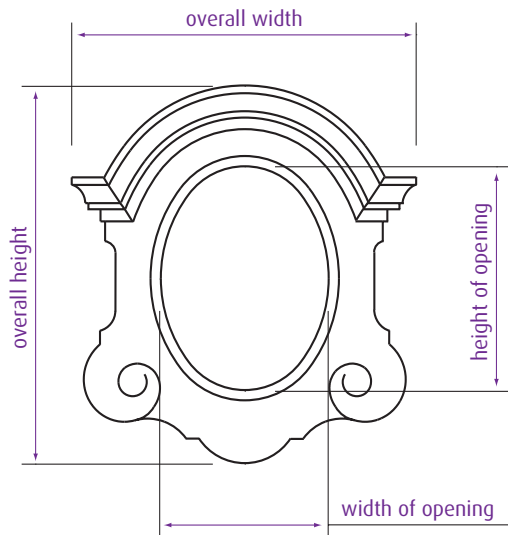

■ Quantity..... ..

■ Roofing material

slate..... ..

tile..... ..

metal..... ..

■ Opening

height..... ..

width..... ..

■ Façade only..... ..

■ slope straight..... ..

imperial..... ..

dome..... ..

■ Slope (dimension of A mandatory)..... ..

do not give degree or percentage.

Give horizontal length A for a vertical length of 1m. E.g. 0.8m horizontal for 1 vertical metre.

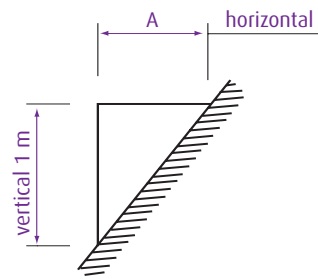
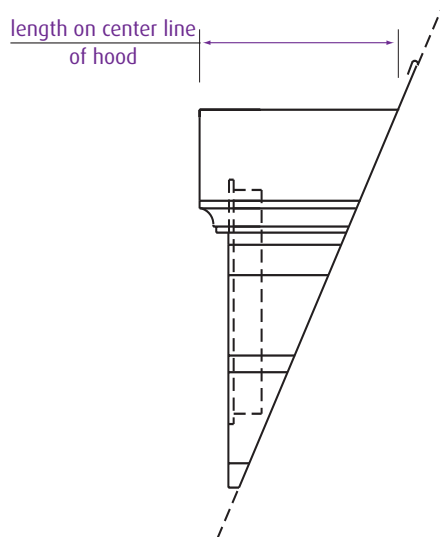

bull's eye

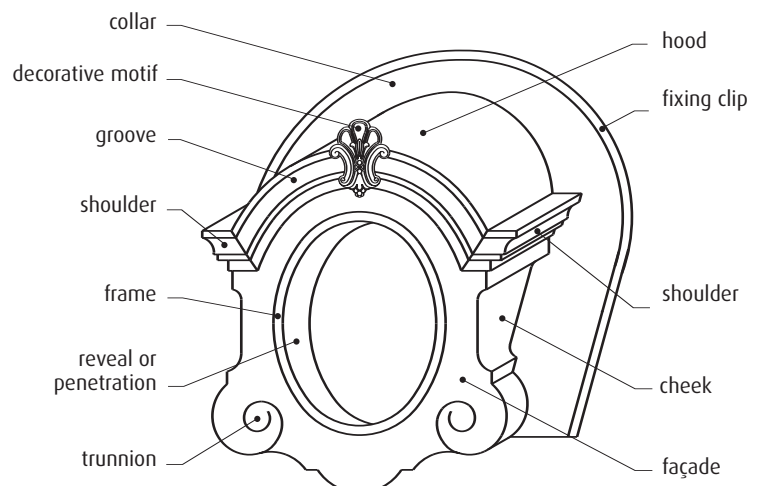

you must attach a good quality photo to your request showing as details as many possible.